

REVISIONS					
REV	ECO	DATE	REVISED	CHECKED	APPROVED
A		10/4/2010			

**SOLATUBE 160 DS  
(10 IN / 250 MM)  
COMPACT FLUORESCENT  
LIGHT KIT**

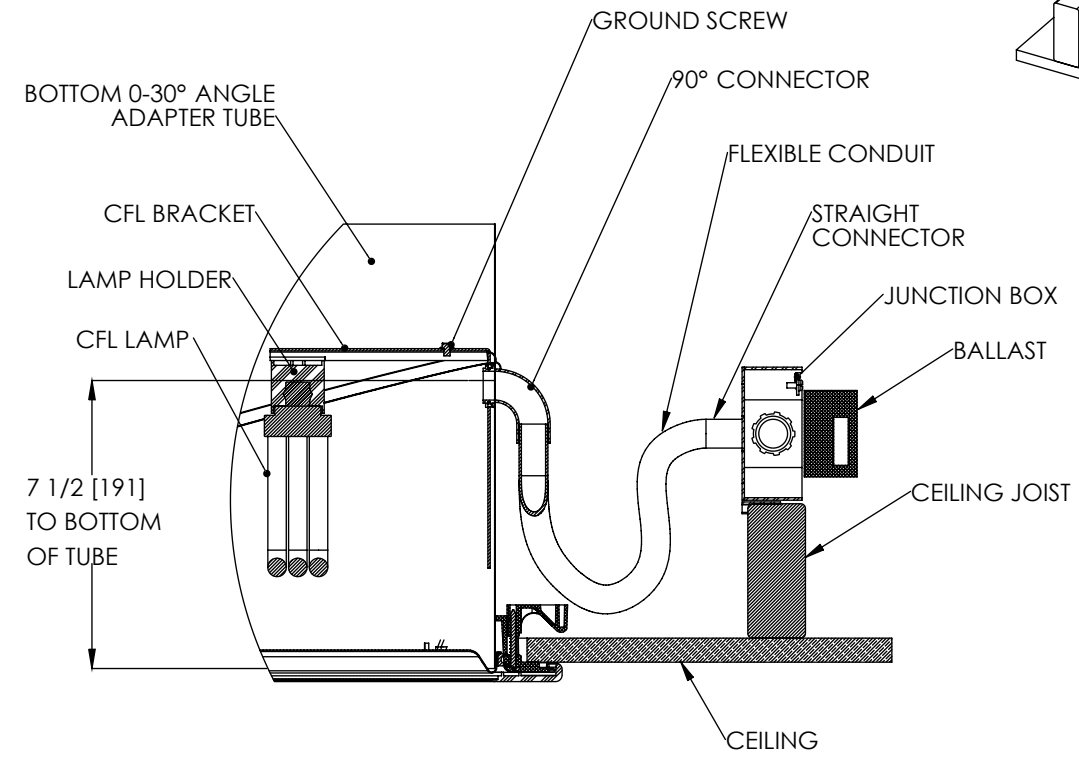

**DETAIL B  
SCALE 2 : 1**

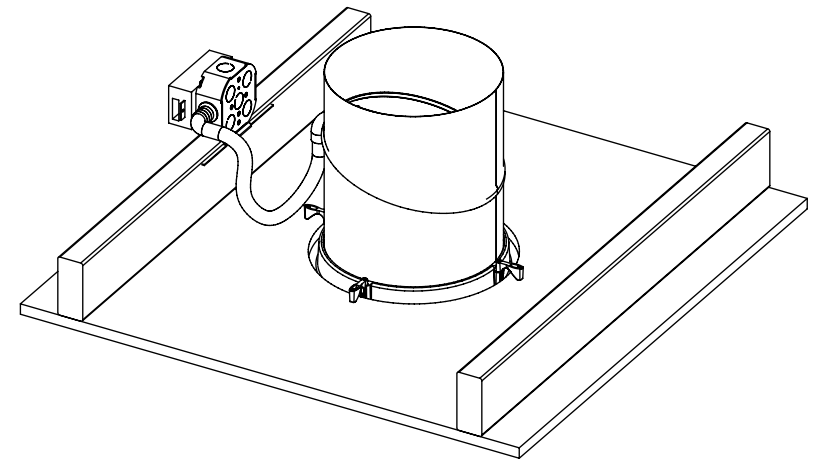
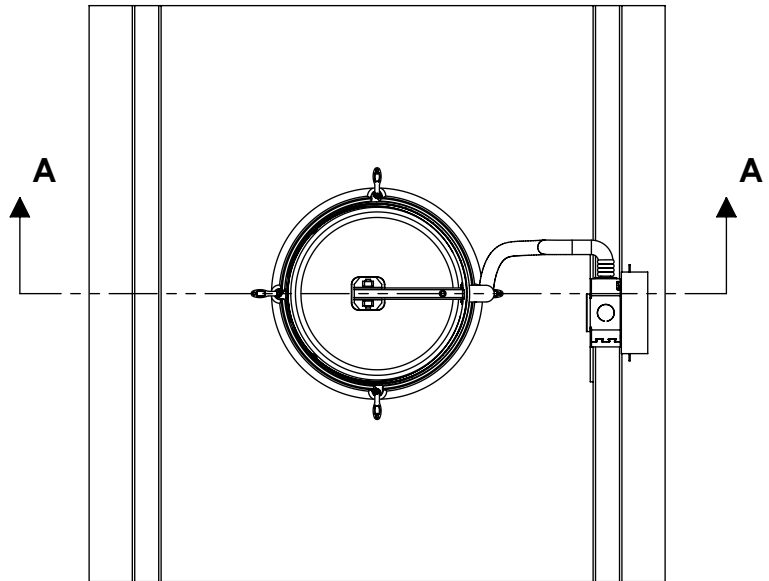
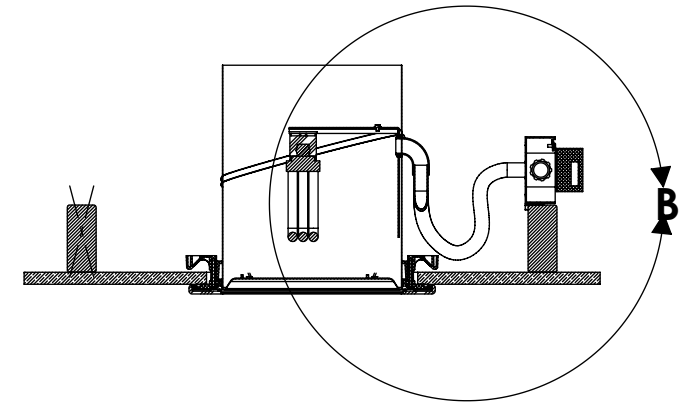

**SECTION A-A**

**NOTES:**

1. STRUCTURAL ELEMENTS (PLYWOOD, RAFTERS, DRYWALL ETC. BY OTHERS & SHOWN FOR REFERENCE ONLY).
2. ALL TUBE JOINTS & SEAMS TAPED WITH 2" FOIL TAPE (NOT SHOWN).
3. DIMENSIONS IN BRACKETS ARE METRIC UNLESS OTHERWISE SPECIFIED.
4. 6" MIN CLEARANCE SHOULD BE MAINTAINED FROM ALL SOLATUBE COMPONENTS AND OTHER PLENUM COMPONENTS.
5. CFL LAMP: USE GX24q-3 BASE, 26 WATT; 4-PIN ONLY

UNLESS OTHERWISE SPECIFIED:		SOLATUBE INTERNATIONAL, INC. COPYRIGHT 2010 WWW.SOLATUBE.COM		 <b>SOLATUBE</b> <small>22' J OAK RIDGE WAY WESTLAKE, CALIFORNIA 91361-3341 PH: (714) 527-4400</small>	
DIMENSION TOLERANCE		DRAWN BY STEVENS		DATE 10/4/10	
FRACTIONS ± 1/4"		CHECKED BY		DATE	
INCH X ± .1		APPROVED BY		DATE	
MILLIMETER XX ± .06 [XX] ± 1.5		DO NOT SCALE DRAWING		TITLE: <b>SOLATUBE 160 DS COMPACT FLUORESCENT LIGHT</b>	
				SIZE: DWG. NO. <b>WEB-160DS-HC-CFL</b>	
				REV <b>A</b>	
				SCALE: 1:1	
				SHEET 1 OF 1	